

Circuit Diagram of Connectors (Version 3.0 Edit 67) for layout version 02

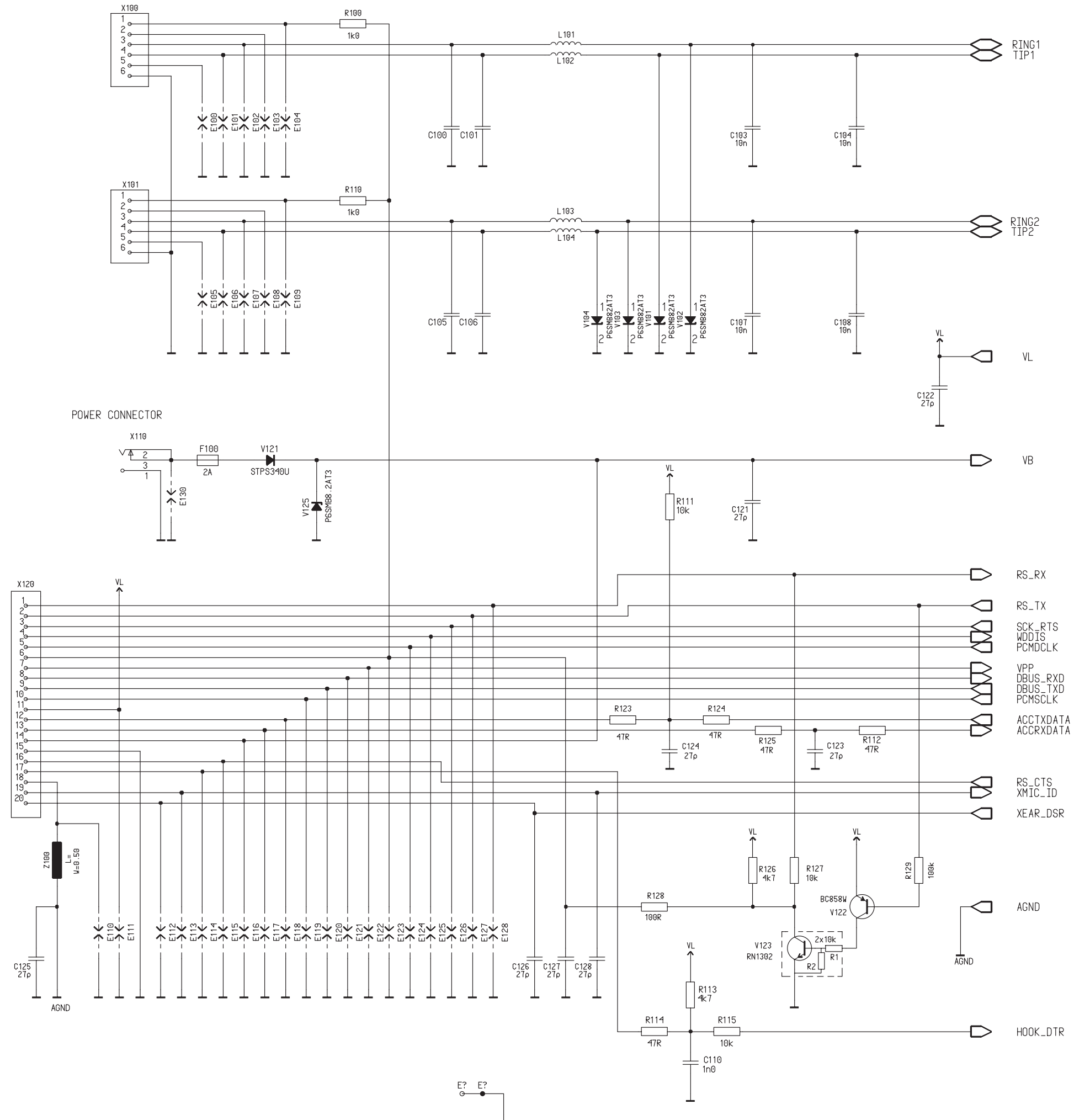

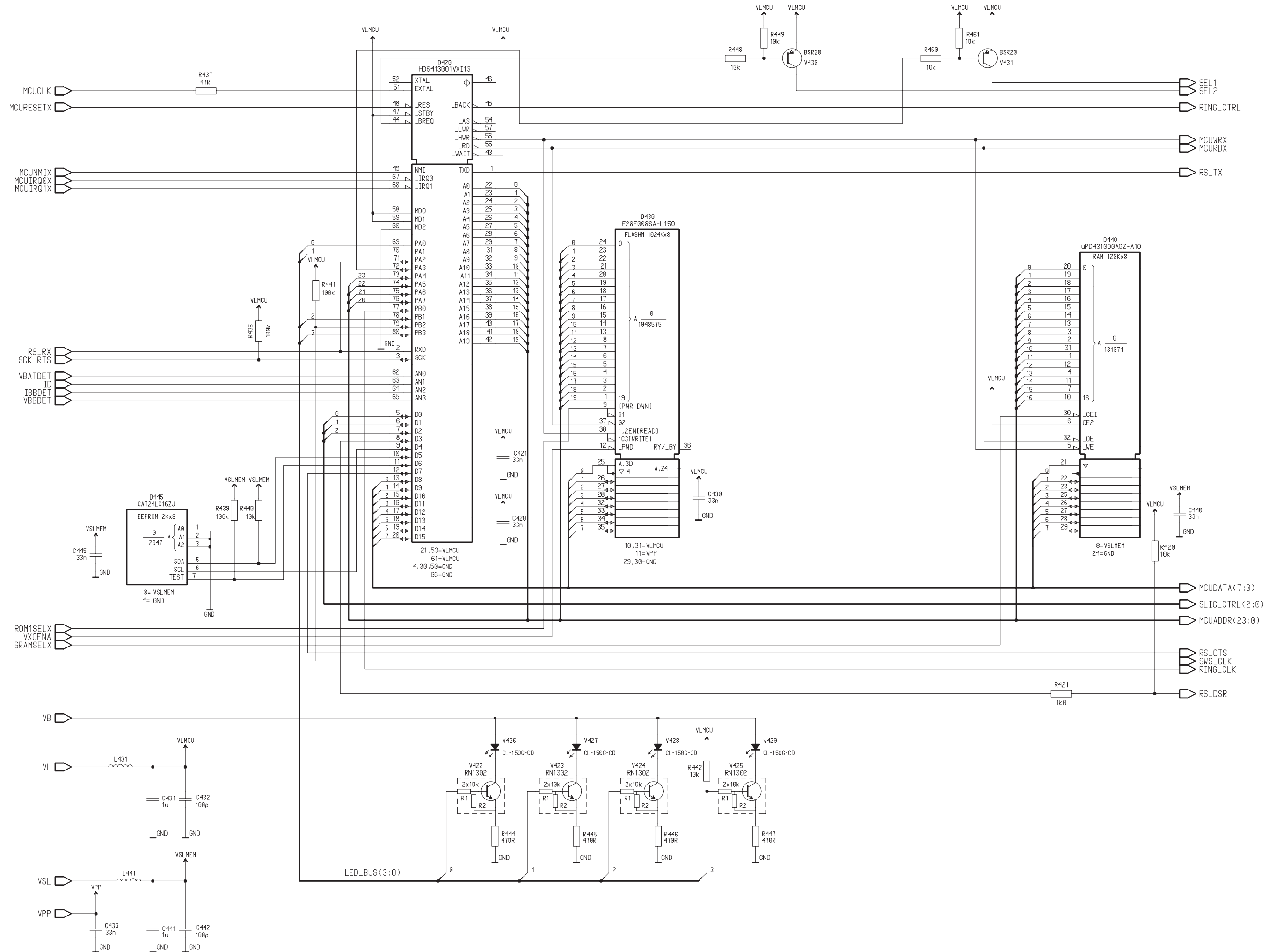

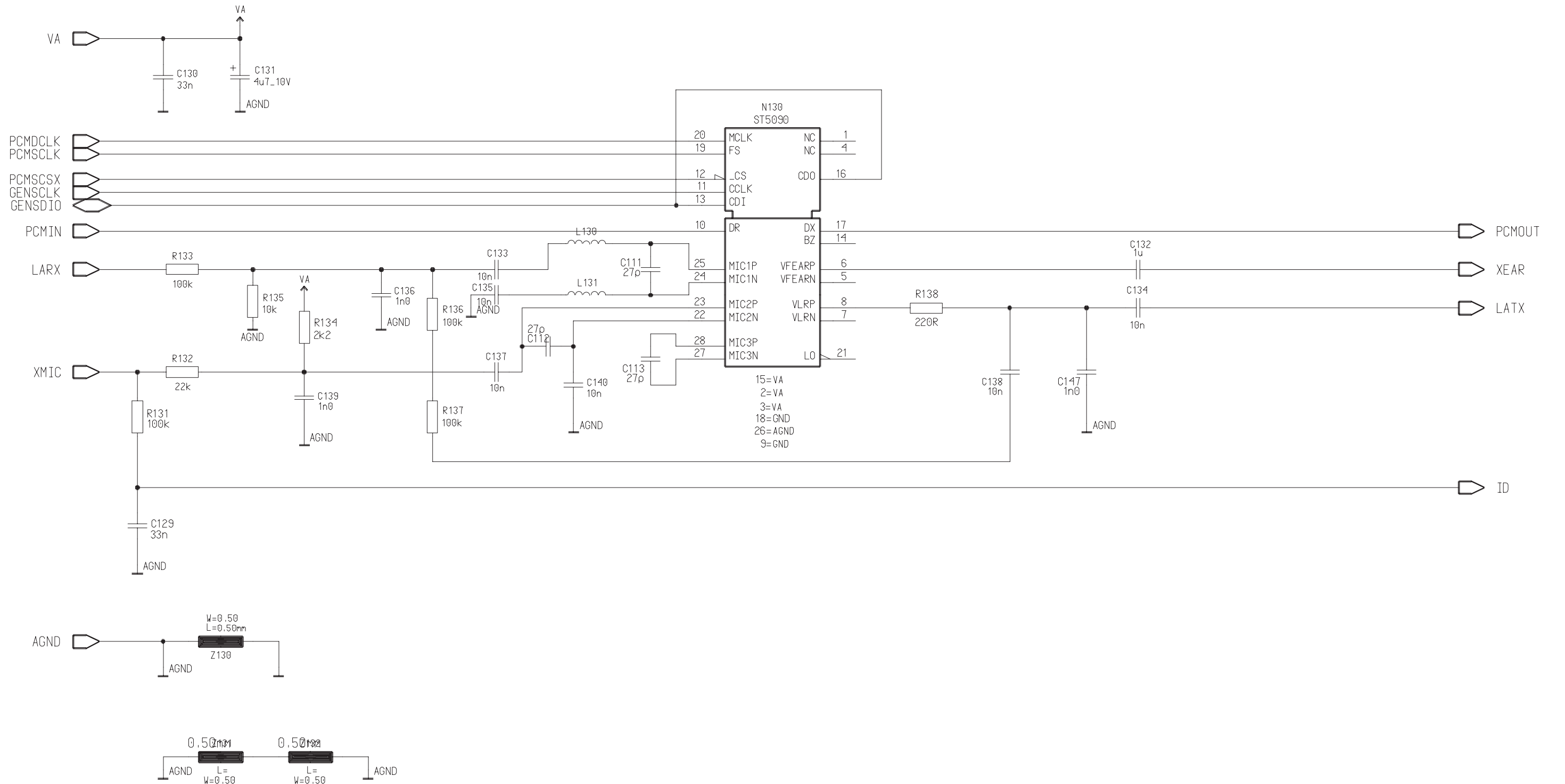

Circuit Diagram of ASIC (Version 3.0 Edit 45) for layout version 02

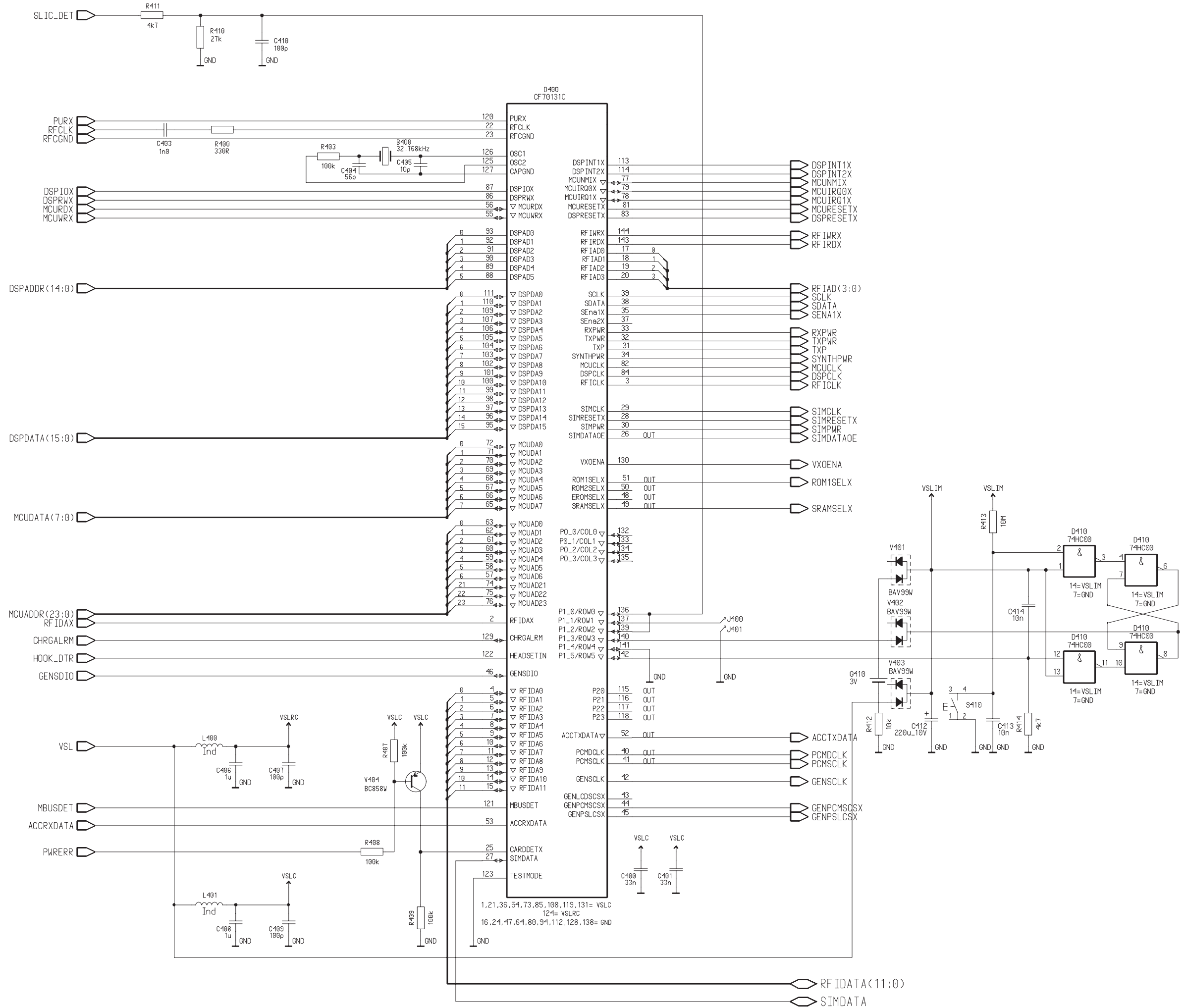

Circuit Diagram of DSP Memory Block (Version 3.0 Edit 32) for layout version 02

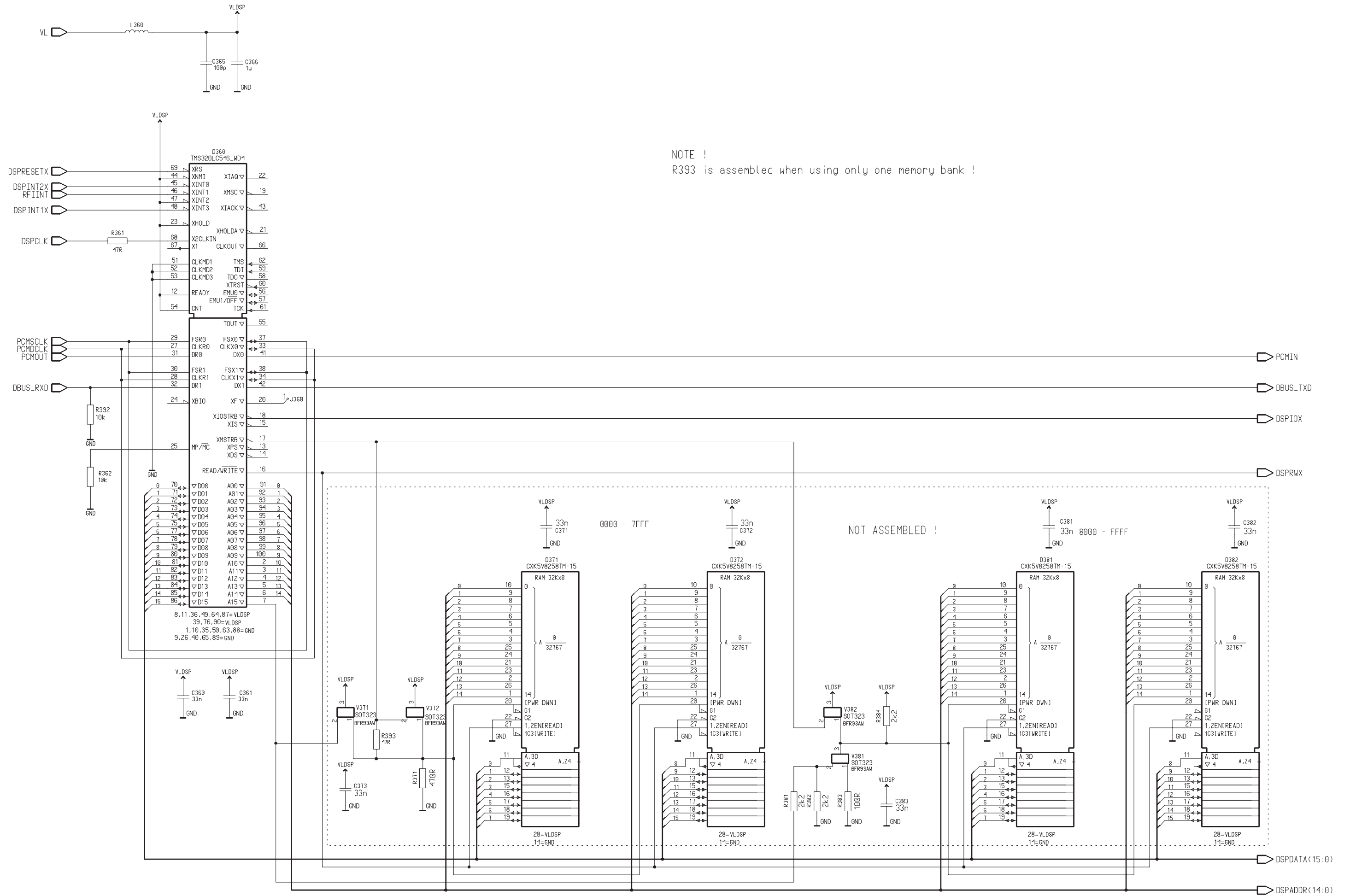

Circuit Diagram of RFI (Version 3.0 Edit 73) for layout version 02

